

MOLTIPLICATORI-RIDUTTORI-RINVI-INGRANAGGI
 OVER GEARS-REDUCTION GEARS-DRIVING GEARS-GEARS

Via S.Giovanni,48 - 36045 Lonigo - VI
 Tel. 0444 831205 - Fax 0444 834972
 www.cmviduttori.it - e-mail - info@cmviduttori.it

MA86S

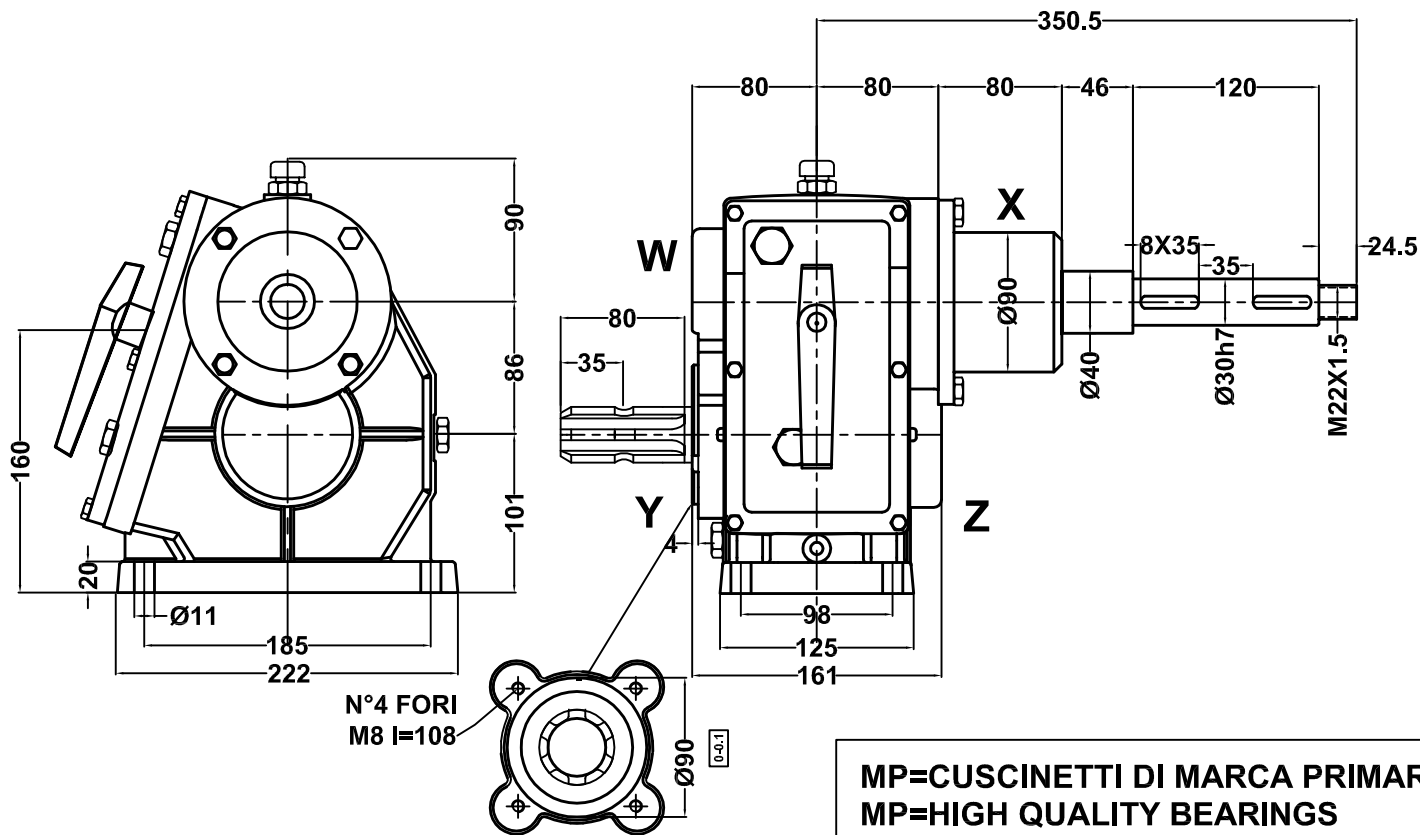

MP=CUSCINETTI DI MARCA PRIMARIA
MP=HIGH QUALITY BEARINGS
FAG-SKF-NSK-KOYO-TIMKEN

IMPIEGHI PRINCIPALI:
 MAIN APPLICATION:

	RAPPORTO GEAR RATIO	GIRI ENTRATA INPUT REV.	POTENZA ENTRATA INPUT POWER		COPPIA TORQUE	GIRI USCITA OUTPUT REV.	CODICE CODE	CUSINETTI BEARINGS
		<i>giri/min - rpm</i>	<i>CV</i>	<i>kW</i>	<i>Nm</i>	<i>giri/min - rpm</i>		
MOLTIPLICATORI OVERDRIVE GEARS	1:4	540	30	22	98	2160	ZMA86S11	X 6208 MP
	1:3.12	540	30	22	120	1684		W 6306 MP
	1:4.5	540	30	22	87	2430		Y 6207 MP
	1:4	540	30	22	98	2160	ZMA86S	Z 6207 MP
							Olio consigliato Recommended oil grade SAE 150 KG.1.2	PESO WEIGHT kg.24
MATERIALI MATERIALS	ALBERI/SHAFTS	INGRANAG./GEARS	SCATOLA/BOX	DENTATURA/ TOOTHING				E.
	18NiCrMo5	18NiCrMo5	GHISA G25 CAST IRON G25	DENTI ELICOIDALI,SBARBATI, C.T.R C.T.R HELICOIDAL AND SHAVED TOOTH				



I gruppi vengono forniti senza olio; provvedere al riempimento fino al livello prima della messa in opera.
 The units are supplied without oil; before use fill, at to the correct level.