

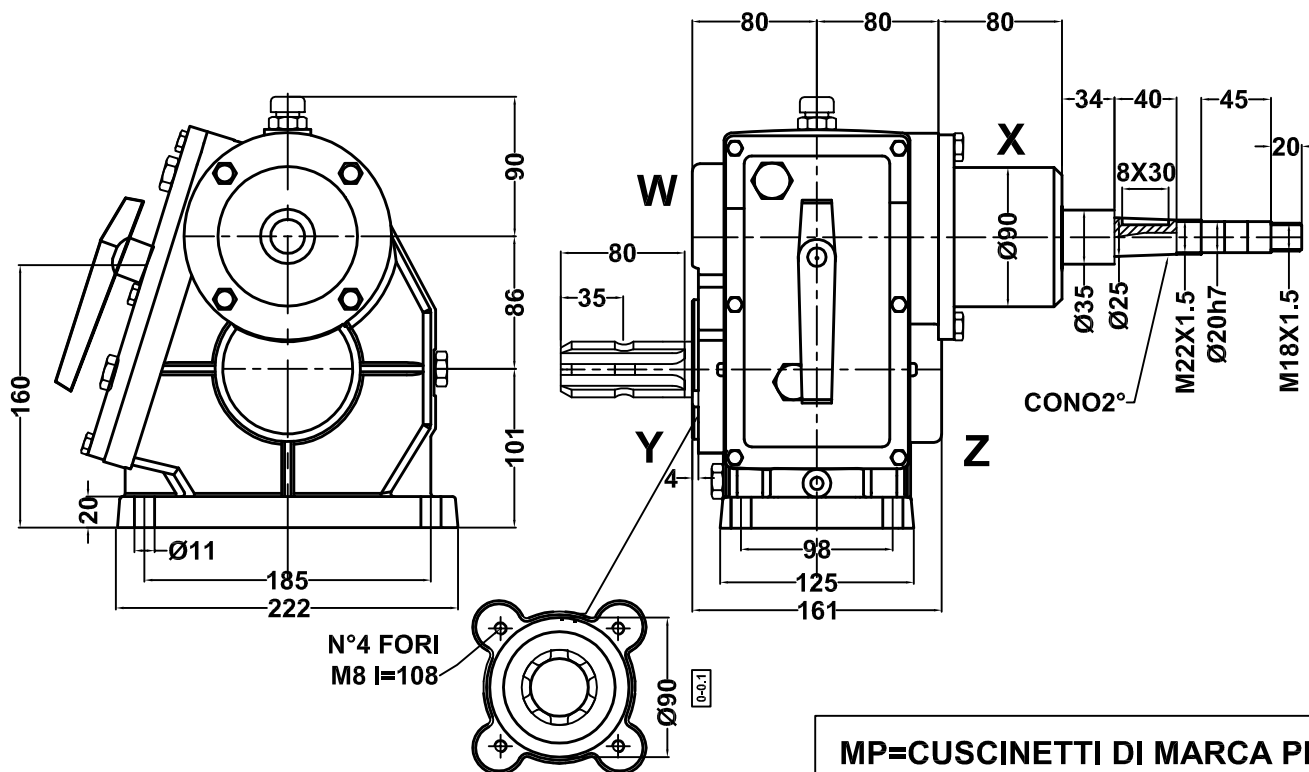

MOLTIPLICATORI-RIDUTTORI-RINVII-INGRANAGGI  
 OVER GEARS-REDUCTION GEARS-DRIVING GEARS-GEARS

Via S.Giovanni,48 - 36045 Lonigo - VI  
 Tel. 0444 831205 - Fax 0444 834972  
 www.cmviduttori.it - e-mail - info@cmviduttori.it

# MA86S



**MP=CUSCINETTI DI MARCA PRIMARIA**  
**MP=HIGH QUALITY BEARINGS**  
**FAG-SKF-NSK-KOYO-TIMKEN**

IMPIEGHI PRINCIPALI:  
 MAIN APPLICATION:

	RAPPORTO GEAR RATIO	GIRI ENTRATA INPUT REV.	POTENZA ENTRATA INPUT POWER		COPPIA TORQUE	GIRI USCITA OUTPUT REV.	CODICE CODE	CUSINETTI BEARINGS	
		<i>giri/min - rpm</i>	<i>CV</i>	<i>kW</i>	<i>Nm</i>	<i>giri/min - rpm</i>			
MOLTIPLICATORI OVERDRIVE GEARS	1:4.5	540	30	22	87	2430	MA86S40	X 6208 MP	
	1:4	540	30	22	98	2160		W 6306 MP	
	1:5	540	30	22	78	2700		Y 6207	
	1:4	540	30	22	98	2160	MA86S9	Z 6207	
							Olio consigliato Recommended oil grade	PESO WEIGHT	
							SAE 150	KG.1.2	kg.24
MATERIALI MATERIALS	ALBERI/SHAFTS	INGRANAG./GEARS	SCATOLA/BOX	DENTATURA/ TOOTHING				E.	
	18NiCrMo5	18NiCrMo5	GHISA G25 CAST IRON G25	DENTI ELICOIDALI,SBARBATI, C.T.R C.T.R HELICOIDAL AND SHAVED TOOTH					



I gruppi vengono forniti senza olio; provvedere al riempimento fino al livello prima della messa in opera.  
 The units are supplied without oil; before use fill, at to the correct level.