

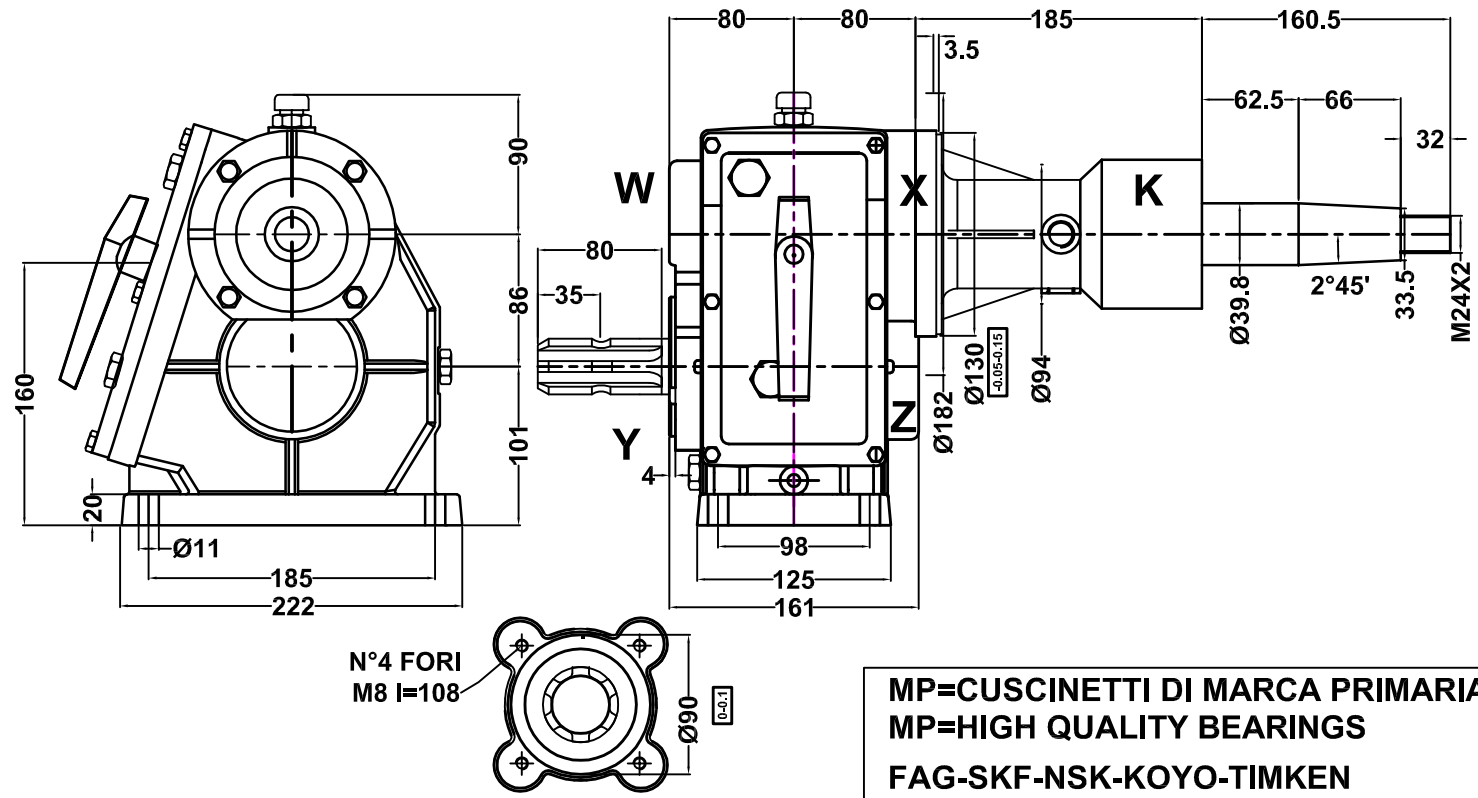

MOLTIPLICATORI-RIDUTTORI-RINVI-INGRANAGGI
 OVER GEARS-REDUCTION GEARS-DRIVING GEARS-GEARS

Via S.Giovanni,48 - 36045 Lonigo - VI
 Tel. 0444 831205 - Fax 0444 834972
 www.cmviduttori.it - e-mail - info@cmviduttori.it

MA86P



**MP=CUSCINETTI DI MARCA PRIMARIA
 MP=HIGH QUALITY BEARINGS
 FAG-SKF-NSK-KOYO-TIMKEN**

IMPIEGHI PRINCIPALI:
 MAIN APPLICATION:

	RAPPORTO GEAR RATIO	GIRI ENTRATA INPUT REV.	POTENZA ENTRATA INPUT POWER		COPPIA TORQUE	GIRI USCITA OUTPUT REV.	CODICE CODE		CUSINETTI BEARINGS
		<i>giri/min - rpm</i>	CV	kW	Nm	<i>giri/min - rpm</i>			
MOLTIPLICATORI OVERDRIVE GEARS							MA86P4540.1		X 6208 MP
									W 6306 MP
									Y 6207 MP
	1:4.5	540	30	22	87	2430			Z 6207 MP
	1:4	540	30	22	98	2160			K 6208 MP
							olio consigliato Recommended oil grade	PESO WEIGHT	
							SAE 150	KG.1.2	kg.24
MATERIALI MATERIALS	ALBERI/SHAFTS	INGRANAG./GEARS	SCATOLA/BOX	DENTATURA/ TOOTHING					
	18NiCrMo5	18NiCrMo5	GHISA G25 CAST IRON G25	DENTI ELICOIDALI,SBARBATI, C.T.R C.T.R HELICOIDAL AND SHAVED TOOTH					

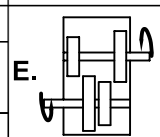

I gruppi vengono forniti senza olio; provvedere al riempimento fino al livello prima della messa in opera.
 The units are supplied without oil; before use fill, at to the correct level.