

MOLTIPLICATORI-RIDUTTORI-RINVI-INGRANAGGI  
 OVER GEARS-REDUCTION GEARS-DRIVING GEARS-GEARS

Via S.Giovanni,48 - 36045 Lonigo - VI  
 Tel. 0444 831205 - Fax 0444 834972  
 www.cmviduttori.it - e-mail - info@cmviduttori.it

## MA139S

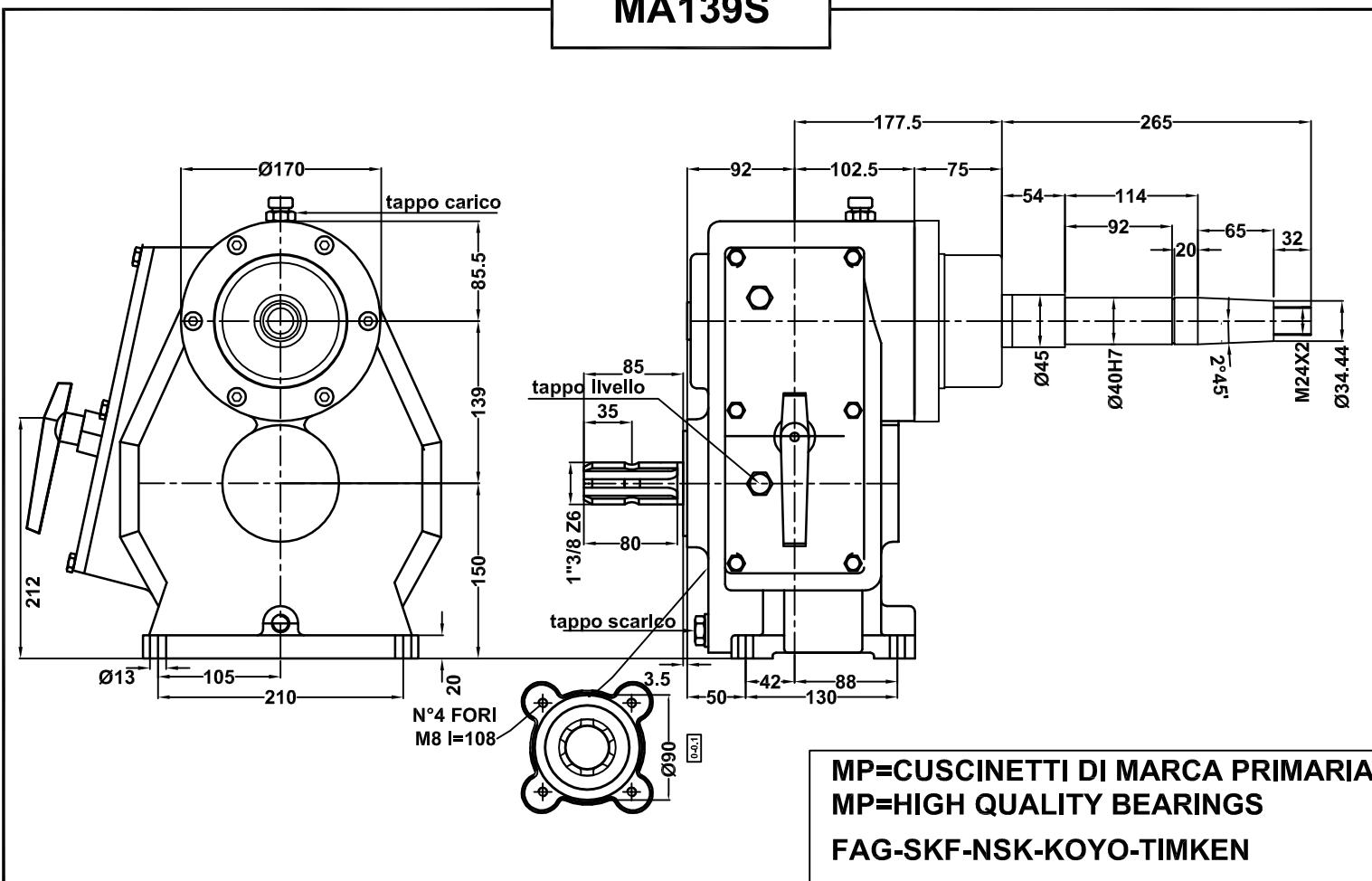

**MP=CUSCINETTI DI MARCA PRIMARIA**  
**MP=HIGH QUALITY BEARINGS**  
**FAG-SKF-NSK-KOYO-TIMKEN**

IMPIEGHI PRINCIPALI:  
 MAIN APPLICATION:

	RAPPORTO GEAR RATIO	GIRI ENTRATA INPUT REV.	POTENZA ENTRATA INPUT POWER		COPPIA TORQUE	GIRI USCITA OUTPUT REV.	CODICE CODE		CUSINETTI BEARINGS
		<i>giri/min - rpm</i>	<i>CV</i>	<i>kW</i>	<i>Nm</i>	<i>giri/min - rpm</i>			
MOLTIPLICATORI OVERDRIVE GEARS	1:6	540	75	55.5	162	3240	MA139S5060		X 6309 MP
	1:5	540	75	55.5	190	2700			W 6407 MP
									Y 6307 MP
									Z 6307 MP
							Olio consigliato Recommended oil grade	PESO WEIGHT	
							SAE 150	KG.2.9	kg.52
MATERIALI MATERIALS	ALBERI/SHAFTS	INGRANAG./GEARS	SCATOLA/BOX	DENTATURA/ TOOTHING					
	18NiCrMo5	18NiCrMo5	GHISA G25 CAST IRON G25	DENTI ELICOIDALI,SBARBATI, C.T.R C.T.R HELICOIDAL AND SHAVED TOOTH					
				E.					



I gruppi vengono forniti senza olio; provvedere al riempimento fino al livello prima della messa in opera.  
 The units are supplied without oil; before use fill, at to the correct level.