

**MA1393V**

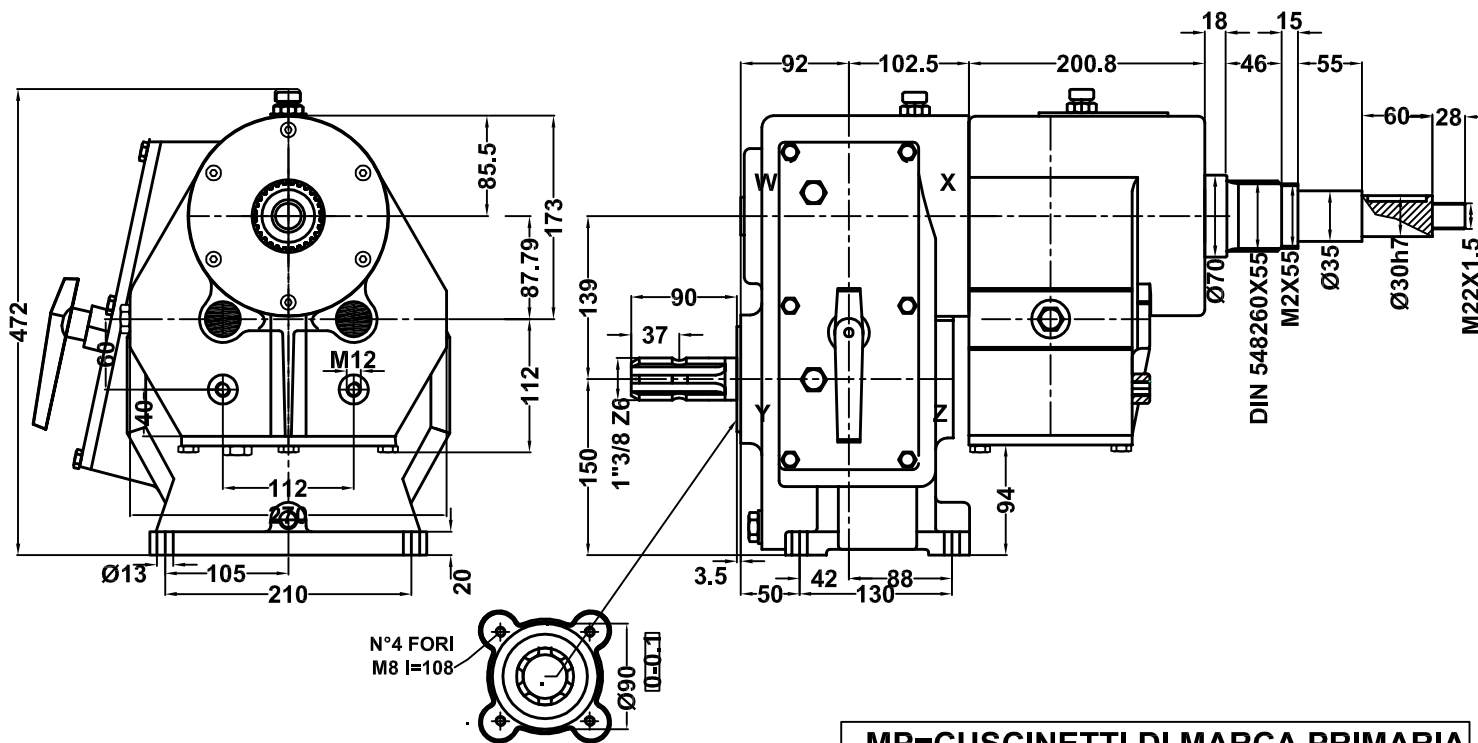

**MP=CUSCINETTI DI MARCA PRIMARIA**  
**MP=HIGH QUALITY BEARINGS**  
**FAG-SKF-NSK-KOYO-TIMKEN**

IMPIEGHI PRINCIPALI:  
 MAIN APPLICATION:

	RAPPORTO GEAR RATIO	GIRI ENTRATA INPUT REV.	POTENZA ENTRATA INPUT POWER		COPPIA TORQUE	GIRI USCITA OUTPUT REV.	CODICE CODE	CUSINETTI BEARINGS	
		<i>giri/min - rpm</i>	<i>CV</i>	<i>kW</i>	<i>Nm</i>	<i>giri/min - rpm</i>			
MOLTIPLICATORI OVERDRIVE GEARS	1:4.57	540	80	59.7	222	2468	MA139A3V	X 6309 MP	
	1:3.52	540	80	59.7	289	1900		W 6407 MP	
									Y 6307 MP
									Z 6307 MP
							Olio consigliato Recommended oil grade	PESO WEIGHT	
							SAE 150 KG.2.9		
							SAE 90 KG.1.9	kg.67	

MATERIALI MATERIALS	ALBERI/SHAFTS	INGRANAG./GEARS	SCATOLA/BOX	DENTATURA/ TOOTHING
		18NiCrMo5	18NiCrMo5	GHISA G25 CAST IRON G25

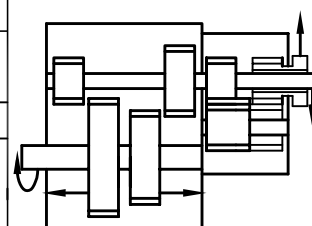

I gruppi vengono forniti senza olio; provvedere al riempimento fino al livello prima della messa in opera.  
 The units are supplied without oil; before use fill, at to the correct level.