

MOLTIPLICATORI-RIDUTTORI-RINVI-INGRANAGGI
 OVER GEARS-REDUCTION GEARS-DRIVING GEARS-GEARS

Via S.Giovanni,48 - 36045 Lonigo - VI
 Tel. 0444 831205 - Fax 0444 834972
 www.cmviduttori.it - e-mail - info@cmviduttori.it

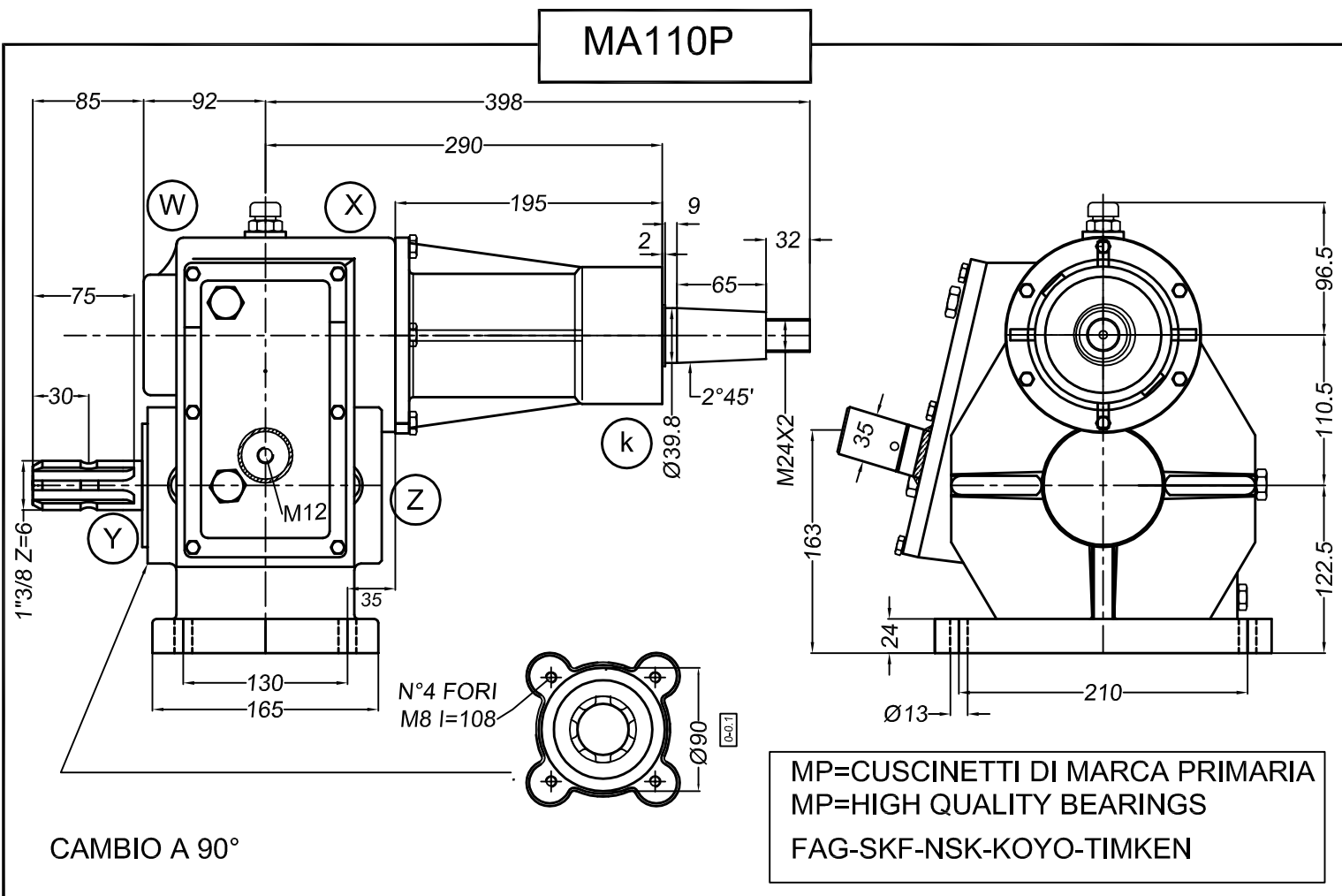

IMPIEGHI PRINCIPALI:
 MAIN APPLICATION:

	RAPPORTO GEAR RATIO	GIRI ENTRATA INPUT REV.	POTENZA ENTRATA INPUT POWER		COPPIA TORQUE	GIRI USCITA OUTPUT REV.	CODICE CODE		CUSINETTI BEARINGS
		<i>giri/min - rpm</i>	<i>CV</i>	<i>kW</i>	<i>Nm</i>	<i>giri/min - rpm</i>			
MOLTIPLICATORI OVERDRIVE GEARS	1:4.5	540	61	45	175	2430	MA110P9		X 6309 MP
	1:3.5	540	59	44	219	1890			W 6307 MP
									Y 6207 MP
									Z 6207 MP
									K 6209 MP
							Olio consigliato Recommended oil grade	PESO WEIGHT	
							SAE 150	KG.1.9	kg.40
MATERIALI MATERIALS	ALBERI/SHAFTS	INGRANAG./GEARS	SCATOLA/BOX	DENTATURA/ TOOTHING					
	18NiCrMo5	18NiCrMo5	GHISA G25 CAST IRON G25	DENTI ELICOIDALI, SBARBATI, C.T.R C.T.R HELICOIDAL AND SHAVED TOOTH					

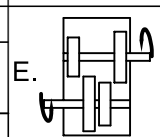

I gruppi vengono forniti senza olio; provvedere al riempimento fino al livello prima della messa in opera.
 The units are supplied without oil; before use fill, at to the correct level.