

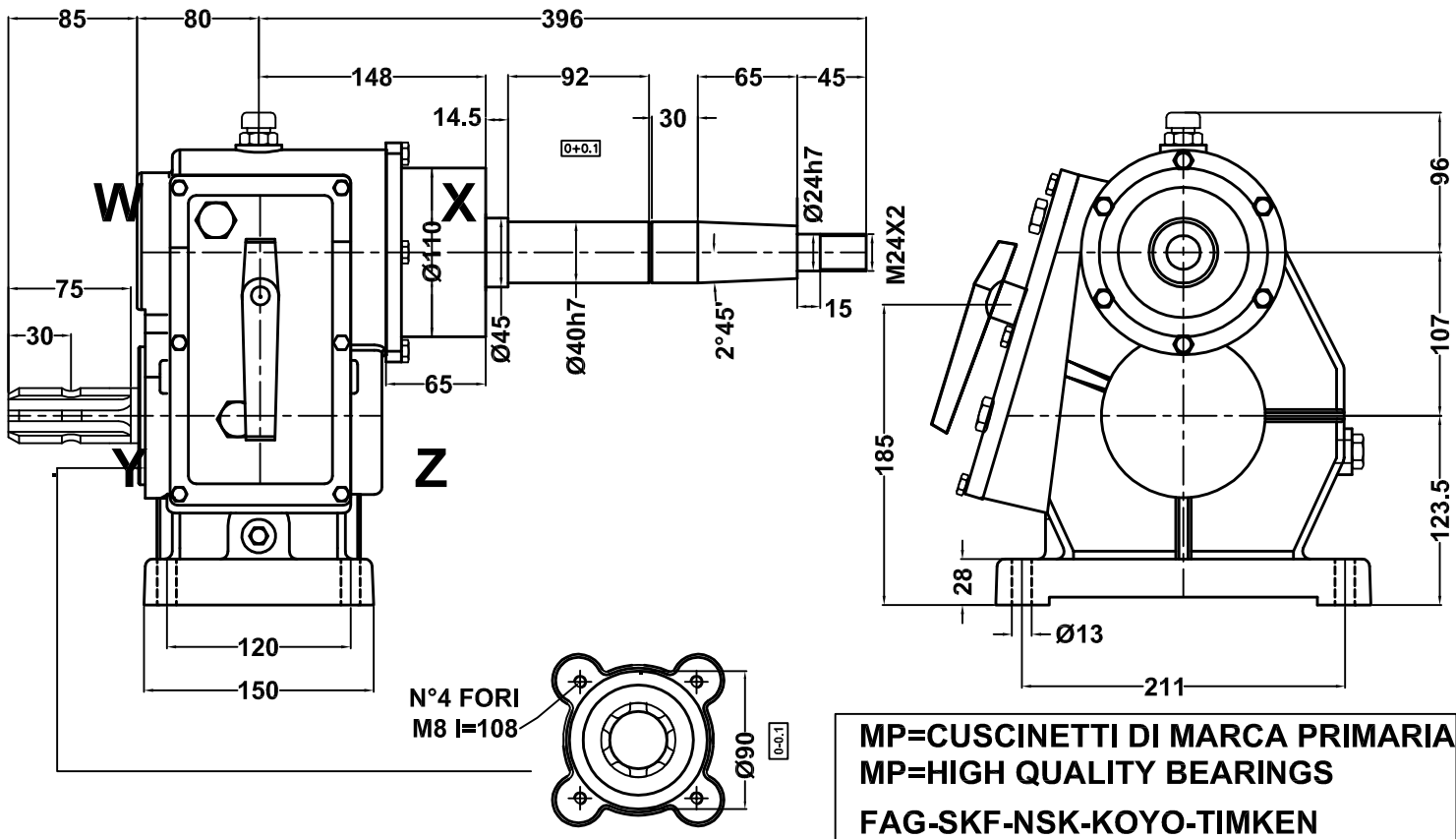

MOLTIPLICATORI-RIDUTTORI-RINVII-INGRANAGGI
OVER GEARS-REDUCTION GEARS-DRIVING GEARS-GEARS

Via S.Giovanni,48 - 36045 Lonigo - VI
Tel. 0444 831205 - Fax 0444 834972
www.cmvridduttori.it - e-mail - info@cmvridduttori.it

MA107S



MP=CUSCINETTI DI MARCA PRIMARIA
MP=HIGH QUALITY BEARINGS
FAG-SKF-NSK-KOYO-TIMKEN

IMPIEGHI PRINCIPALI:
MAIN APPLICATION:

	RAPPORTO GEAR RATIO	GIRI ENTRATA INPUT REV.	POTENZA ENTRATA INPUT POWER		COPPIA TORQUE	GIRI USCITA OUTPUT REV.	CODICE CODE	CUSINETTI BEARINGS	
		<i>giri/min - rpm</i>	<i>CV</i>	<i>kW</i>	<i>Nm</i>	<i>giri/min - rpm</i>			
MOLTIPLICATORI OVERDRIVE GEARS	1:4.4	540	50	37.3	145	2376	MA107S26	X 6209 MP	
	1:3.6	540	50	37.3	181.5	1944		W 6306 MP	
									Y 6207 MP
									Z 6207 MP
							Olio consigliato Recommended oil grade	PESO WEIGHT	
							SAE 150	KG.1.4	
MATERIALI MATERIALS	ALBERI/SHAFTS	INGRANAG./GEARS	SCATOLA/BOX		DENTATURA/ TOOTHING			E.	
	18NiCrMo5	18NiCrMo5	GHISA G25 CAST IRON G25		DENTI ELICOIDALI, SBARBATI, C.T.R C.T.R HELICOIDAL AND SHAVED TOOTH				

I gruppi vengono forniti senza olio; provvedere al riempimento fino al livello prima della messa in opera.
The units are supplied without oil; before use fill, at to the correct level.