

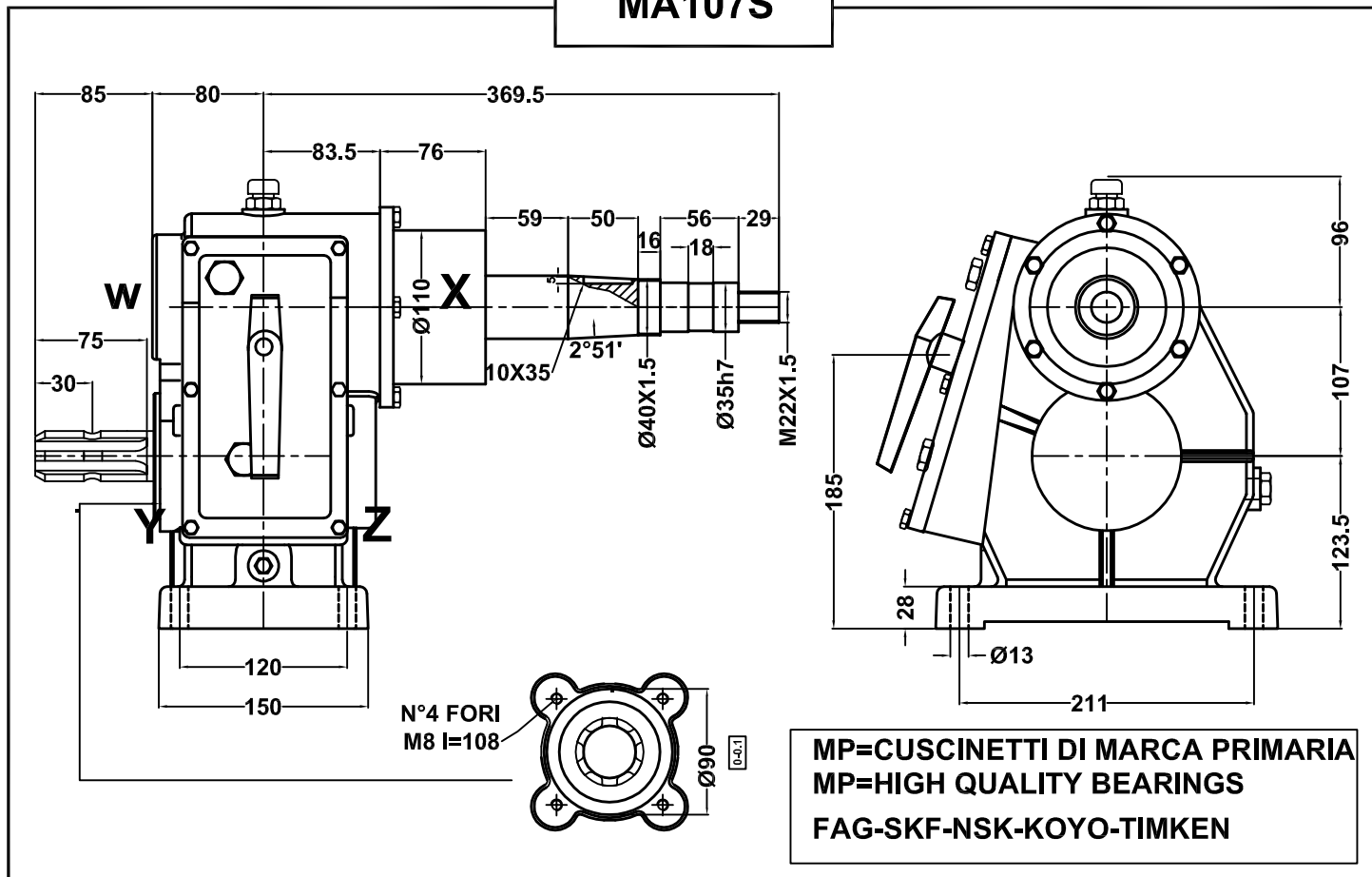

MOLTIPLICATORI-RIDUTTORI-RINVII-INGRANAGGI
OVER GEARS-REDUCTION GEARS-DRIVING GEARS-GEARS

Via S.Giovanni,48 - 36045 Lonigo - VI
Tel. 0444 831205 - Fax 0444 834972
www.cmviduttori.it - e-mail - info@cmviduttori.it

MA107S



IMPIEGHI PRINCIPALI:
MAIN APPLICATION:

| | RAPPORTO GEAR RATIO | GIRI ENTRATA INPUT REV. <i>giri/min - rpm</i> | POTENZA ENTRATA INPUT POWER | | COPPIA TORQUE Nm | GIRI USCITA OUTPUT REV. <i>giri/min - rpm</i> | CODICE CODE | CUSCINETTI BEARINGS | |
|-----------------------------------|------------------------|---|--------------------------------|---|------------------------|---|---|------------------------|-------|
| | | | CV | kW | | | | | |
| MOLTIPLICATORI OVERDRIVE GEARS | 1:5 | 540 | 48 | 35.3 | 125 | 2760 | MA107S7 | X 6209 MP | |
| | 1:4 | 540 | 50 | 37.3 | 160 | 2160 | | W 6306 MP | |
| | | | | | | | | Y 6207 | |
| | | | | | | | | Z 6207 | |
| | | | | | | | Olío consigliato Recommended oil grade | PESO WEIGHT | |
| | | | | | | | SAE 150 | KG.1.4 | kg.34 |
| MATERIALI MATERIALS | ALBERI/SHAFTS | INGRANAG./GEARS | SCATOLA/BOX | DENTATURA/ TOOTHING | | | | E. | |
| | 18NiCrMo5 | 18NiCrMo5 | GHISA G25 CAST IRON G25 | DENTI ELICOIDALI,SBARBATI, C.T.R C.T.R HELICOIDAL AND SHAVED TOOTH | | | | | |



I gruppi vengono forniti senza olio; provvedere al riempimento fino al livello prima della messa in opera.
The units are supplied without oil; before use fill, at to the correct level.