

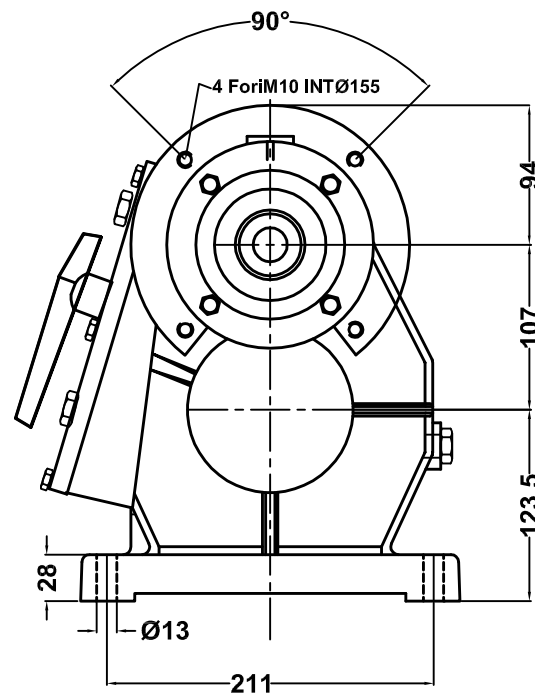

MOLTIPLICATORI-RIDUTTORI-RINVI-INGRANAGGI  
 OVER GEARS-REDUCTION GEARS-DRIVING GEARS-GEARS

Via S.Giovanni,48 - 36045 Lonigo - VI  
 Tel. 0444 831205 - Fax 0444 834972  
 www.cmvriduttori.it - e-mail - info@cmvriduttori.it

# MA107F

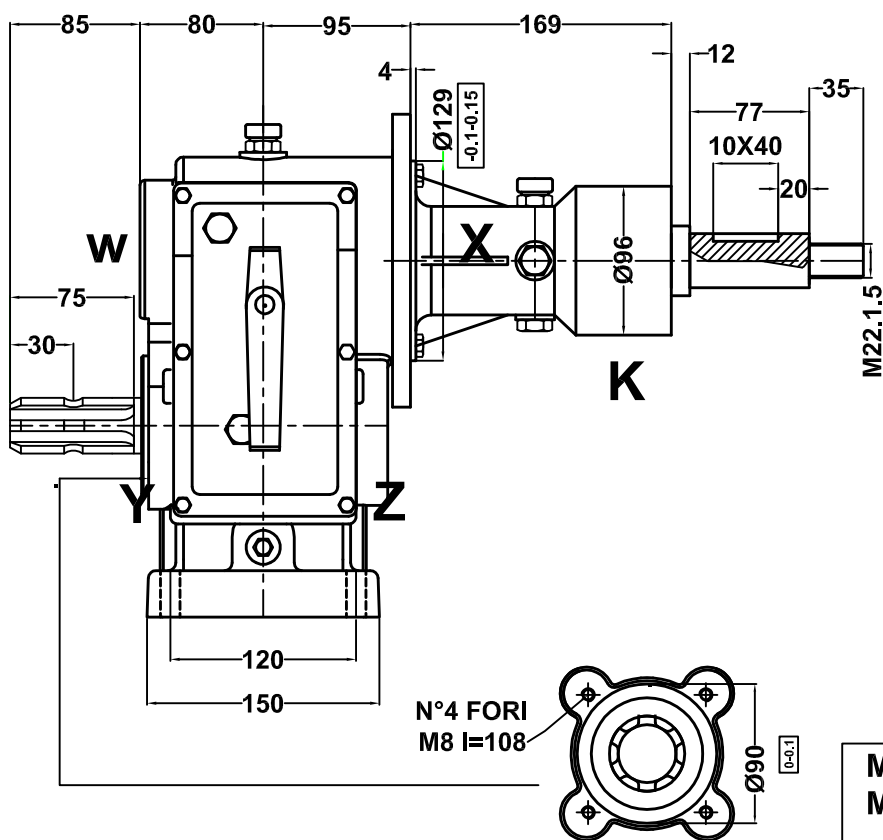

**MP=CUSCINETTI DI MARCA PRIMARIA**  
**MP=HIGH QUALITY BEARINGS**  
**FAG-SKF-NSK-KOYO-TIMKEN**

IMPIEGHI PRINCIPALI:  
 MAIN APPLICATION:

	RAPPORTO GEAR RATIO	GIRI ENTRATA INPUT REV.	POTENZA ENTRATA INPUT POWER		COPPIA TORQUE	GIRI USCITA OUTPUT REV.	CODICE CODE	CUSINETTI BEARINGS
		<i>giri/min - rpm</i>	<i>CV</i>	<i>kW</i>	<i>Nm</i>	<i>giri/min - rpm</i>		
MOLTIPLICATORI OVERDRIVE GEARS	1:4.6	540	46	33.8	134	2430	MA107F3646	X 6207 MP
								W 6207 MP
	1:3.6	540	44	32.3	160.5	1944		Y 6207
	1:5	540	48	35.2	126	2700	MA107F4050	Z 6207
	1:4	540	45	33	147	2160		K 6207 MP
						Olio consigliato Recommended oil grade	PESO WEIGHT	
						SAE 150	KG.1.4	kg.34
MATERIALI MATERIALS	ALBERI/SHAFTS	INGRANAG./GEARS	SCATOLA/BOX	DENTATURA/ TOOTHING				E.
	18NiCrMo5	18NiCrMo5	GHISA G25 CAST IRON G25	DENTI ELICOIDALI,SBARBATI, C.T.R C.T.R HELICOIDAL AND SHAVED TOOTH				



I gruppi vengono forniti senza olio; provvedere al riempimento fino al livello prima della messa in opera.  
 The units are supplied without oil; before use fill, at to the correct level.